

AssetCapture™

AssetCapture is a fast, reliable and unique solution from Cad-Capture for converting property portfolios into **intelligent CAD files™**, effectively and accurately. AssetCapture automates the process of data capture and integrates the intelligent CAD files™ with a range of leading asset management, facilities management and property management systems.

Asset management is traditionally a complex, costly and time-consuming exercise. There are many systems available on the market but they are only as good as the information that is held within them.

This is where AssetCapture and its intelligent CAD files™ come into their own. The ability to populate databases accurately, automatically and directly from the intelligent CAD files™ can reap major benefits in reduced time, lower costs, increased efficiency, improved accuracy and better presentation of information.

AssetCapture enables you to maximise your existing resources and benefits any organisation with a property portfolio.



"Cad-Capture provided an excellent service, completing the project to a very high standard and ahead of the deadline. We were very impressed by the Quality Assurance procedures and the way Cad-Capture operates as a company."

Bob Baber, *Chief Surveyor, Property Services,*
Somerset County Council.

"This is an immense task for any authority to undertake and it has been very reassuring to find a company that has been perfectly capable of assisting in the task but more importantly, willing to listen and be adaptable in satisfying this particular Council's requirements."

John Collins, *Principal Architect,*
Buckinghamshire County Council.

Process Flow Diagram

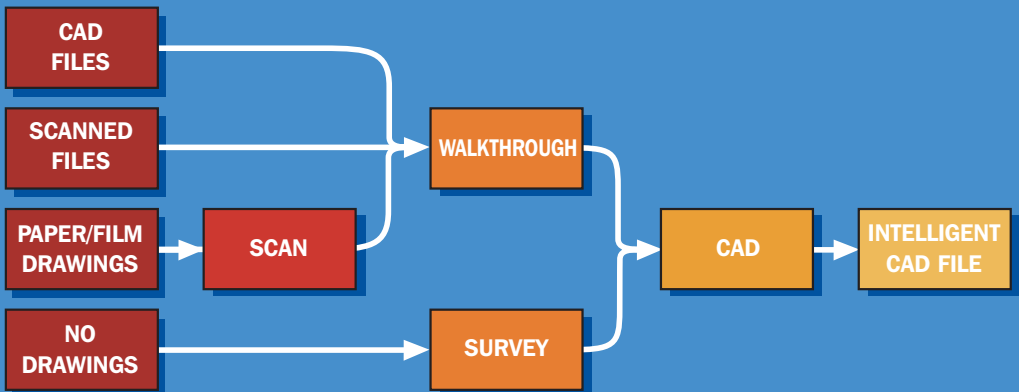

www.assetcapture.net

Tel: 01254 504450

AssetCapture™

Edit Attributes

Block name: ROOM

ROOM_REF	004
ROOM_USE1	A2
ROOM_USE2	Meeting Room
ROOM_CAT	130
ROOM_AREA	16.1
ROOM_PERIM	16.2
ROOM_INCLUDED_AREA	16.1
ROOM_EXCLUDED_AREA	0

OK Cancel Previous Next Help

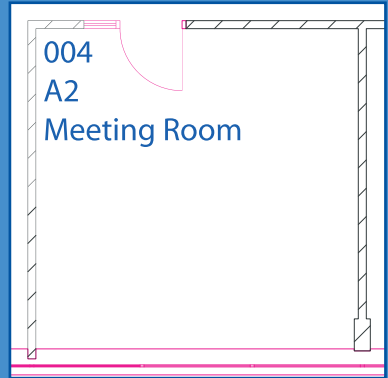

Edit Attributes

Block name: BUILDING

BUILDING_NAME	Head Office
FLOOR_NAME	Ground Floor
GEA	547.2
GIA	506.1
TRA	491.3
NIA	255.8
ESTAB_REF	123/1234
BUILDING_REF	A

OK Cancel Previous Next Help

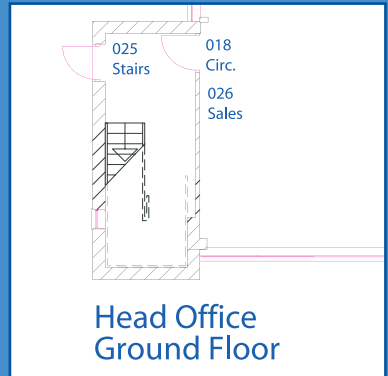

Edit Attributes

Block name: ASBESTOS

ASB_REF	1
ASB_PIC_REF	\\ImageServer\Asbestos\008_01.jpg
ASB_SAMPLE_REF	SAM008_01
ASB_LOCATION	008
ASB_PRODUCT_TYPE	Amosite Sheet
ROOM_REF	8
EST_REF	123/1234
BUILDING_REF	A

OK Cancel Previous Next Help

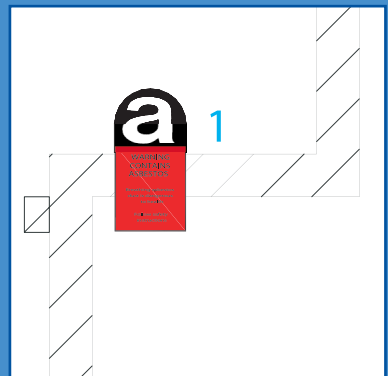

M information ca

Scan

Any relevant media may be scanned, regardless of size, condition or format e.g. architectural drawings, block plans and microfilms etc. The scanned images can be saved to DVD/CD or a document management system, which can save on required storage space and retrieval time. Cad-Capture can assist you in the search for existing media.



Walkthrough

The walkthrough service involves an on-site comparison with your existing media. Details such as room numbers, usage and minor modifications are recorded and incorporated into the intelligent CAD file.

Survey

Cad-Capture's surveying services range from external and internal area surveys through to full measured building surveys, using laser measuring equipment. Any of these services can be specifically tailored to suit your requirements.

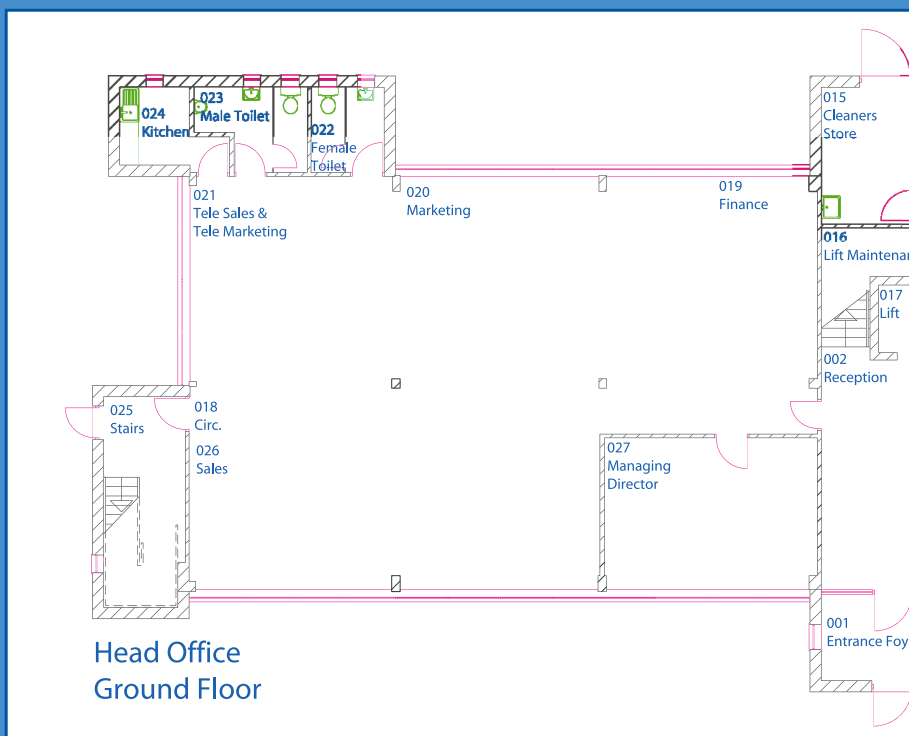

capture for asset

CAD

Utilising Cad-Capture's unique AssetCapture software, property data is automatically generated and CAD attribute blocks are inserted into each space. The overall process is significantly faster than normal CAD drafting procedures. This efficiency benefits you in terms of speed, accuracy, consistency and reduced cost.

ISO layered intelligent CAD files are an invaluable resource for determining the current state of existing assets, as well as providing a single point of reference for future project planning and implementation.

AssetCapture can also add intelligence to your existing CAD files improving integration with property management systems

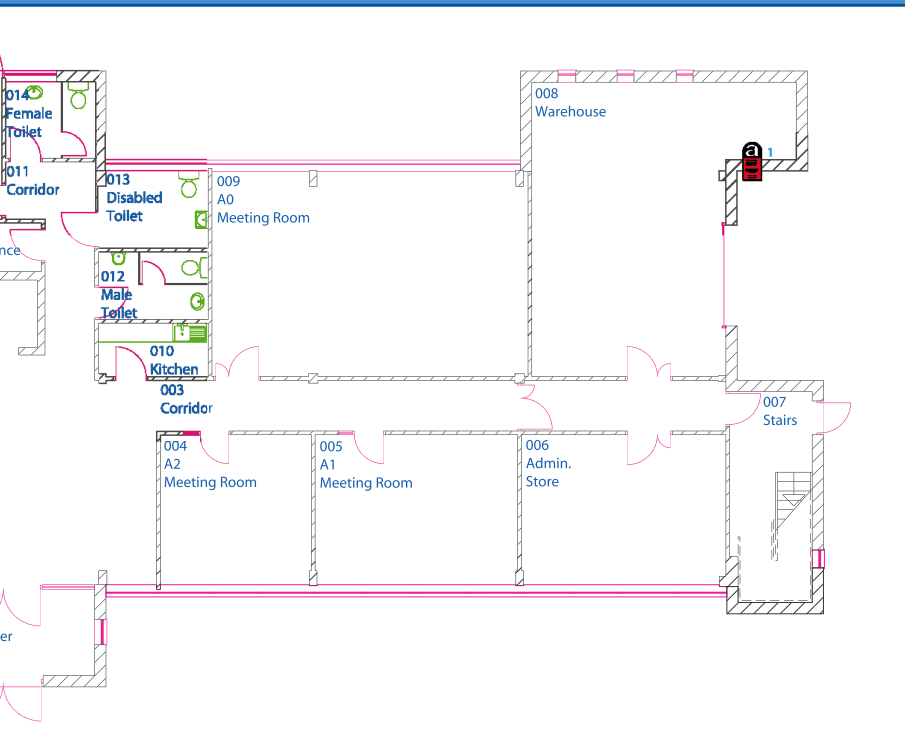

management

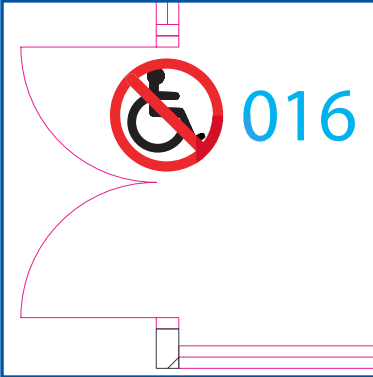

Edit Attributes

Block name: DOOR-DDA

DOOR_REF	016
DOOR_WIDTH	3345
DOOR_HEIGHT	1942
DOOR_DETAILS	Wood, 2 Pane Clear Glass
FIRE_DETAILS	
DDA_DETAILS	<800
ROOM_REF	44
ESTAB_REF	123/1234

OK Cancel Previous Next Help

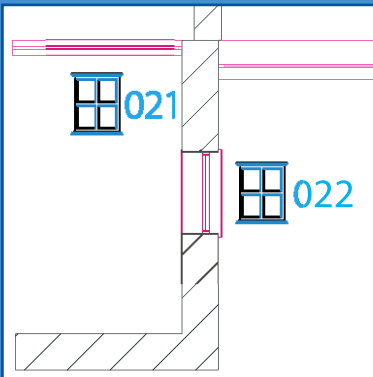

Edit Attributes

Block name: WINDOW

WINDOW_REF	021
CILL_HEIGHT	200
WINDOW_HEIGHT	1800
WINDOW_WIDTH	1400
WINDOW_NOTES	Double glazed Aluminium clear glass
ROOM_REF	1/2
ESTAB_REF	123/1234
BUILDING_REF	A

OK Cancel Previous Next Help

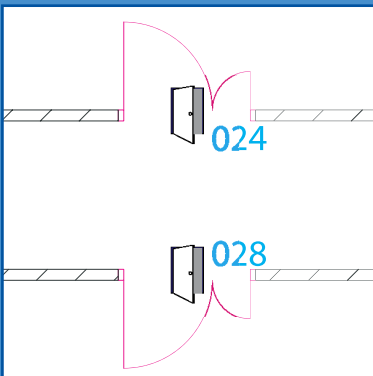

Edit Attributes

Block name: DOOR

DOOR_REF	024
DOOR_WIDTH	2262
DOOR_HEIGHT	1980
DOOR_DETAILS	Wood Fire Door
FIRE_DETAILS	
DDA_DETAILS	
ROOM_REF	8
ESTAB_REF	123/1234

OK Cancel Previous Next Help

Support

Cad-Capture offers comprehensive support and training to ensure you make best use of your intelligent CAD files.



Maintenance

Various levels of maintenance can be supplied. For example:

- Annotated drawings are provided to Cad-Capture and the intelligent CAD file is updated and returned to you as a new revision
- An annual or on-demand contract whereby Cad-Capture's surveyors visit each site, record all changes and incorporate them into the intelligent CAD files



Enhancements

Asset management continues to evolve. Changing requirements such as Government initiatives may dictate the enhancement of intelligent CAD files to new standards. Cad-Capture provides services or software routines to upgrade your intelligent CAD files. For example:

- Extended CAD attribute blocks to include extra information, such as net capacity data
- Multi-language CAD attribute blocks
- Suite analysis CAD attribute block generation
- Room colour shading
- Building elevations and sections
- Digital photographs
- Site plans
- Condition information
- Disabled access
- Asbestos recording

This brochure is intended to give you a brief insight into Cad-Capture's AssetCapture solution, which is continually developing. To understand the full benefits of AssetCapture, please ask for a demonstration.

autodesk[®]
authorised developer



ISO 9001:2000
FS 28730



INVESTOR IN PEOPLE

www.assetcapture.net

Tel: 01254 504450

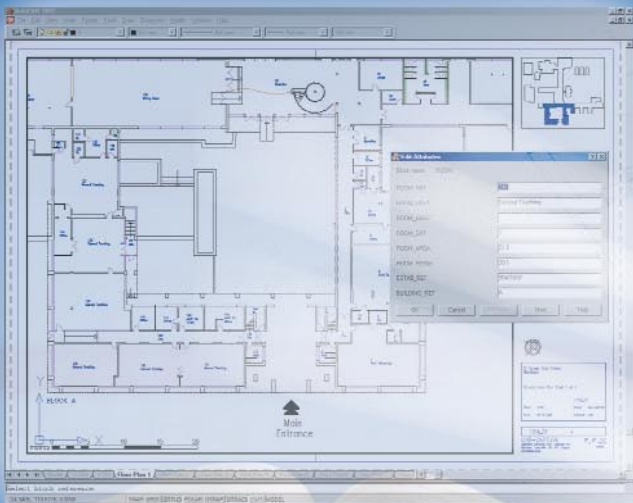

CAD-CAPTURE

Greenbank Technology Park Challenge Way
Blackburn Lancashire BB1 5RR England

T +44 (0)1254 504400
F +44 (0)1254 504401

AssetCapture™
© 2003-2004 Cad-Capture Limited

info@cadcap.co.uk
www.cadcap.co.uk